

Model 7132A Accelerometer



Triaxial IEPE Accelerometer
Miniature Cube
Hermetically Sealed, Titanium
 $\pm 50g$ to $\pm 2000g$ Dynamic Ranges



The **Model 7132A** is a miniature triaxial IEPE accelerometer available in $\pm 50g$ to $\pm 2000g$ dynamic ranges. The accelerometer features a hermetically sealed titanium construction with a 4-pin Microtech connector interface. The model 7132A incorporates stable piezo-ceramic crystals in annular shear mode which provide a flat frequency response up to $>12kHz$.

FEATURES

- 4-pin Connector Interface
- Wide bandwidth up to 12kHz
- Adhesive Mounting
- Miniature Triaxial
- Annular Shear Mode Crystals
- Stable Temperature Response

APPLICATIONS

- Vibration & Shock Monitoring
- Laboratory Testing
- Modal Applications
- High Frequency Applications
- General Purpose Usage
- Stress Screening

dimensions

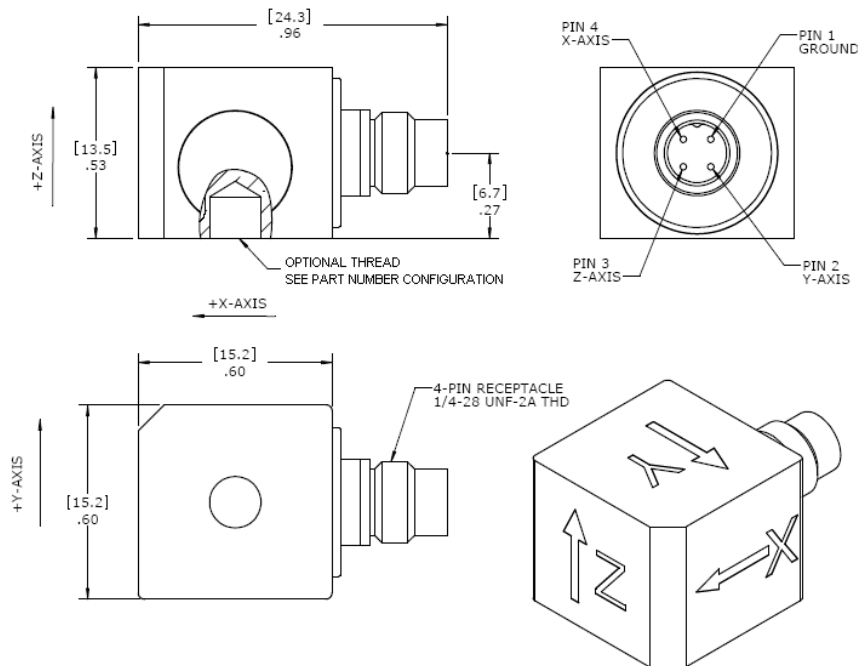

SCHEMATIC (EACH CHANNEL)

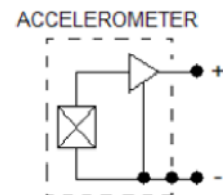

Model 7132A Accelerometer

performance specifications

All values are typical at +24°C, 100Hz and 4mA excitation unless otherwise stated. Measurement Specialties reserves the right to update and change these specifications without notice. Standard product parameters are described in PSC-1003 for Plug & Play AC Accelerometers.

Parameters

	±50	±100	±500	±2000	Notes
DYNAMIC					
Range (g)	±50	±100	±500	±2000	
Sensitivity (mV/g)	100	50	10	2.5	±10%
Frequency Response (Hz)	1-7000	1-7000	1-8000	1-10000	±10%
Frequency Response (Hz)	0.4-9000	0.4-9000	0.4-10000	0.4-12000	±2dB ²
Natural Frequency (Hz)	37000	37000	37000	42000	
Non-Linearity (%FSO)	±1	±1	±1	±1	
Transverse Sensitivity (%)	<5	<5	<5	<5	
Shock Limit (g)	10000	10000	10000	10000	
ELECTRICAL					
Compliance Voltage (Vdc)	18 to 30	18 to 30	18 to 30	18 to 30	
Excitation Current (mA)	2 to 10	2 to 10	2 to 10	2 to 10	
Bias Voltage (Vdc)	8 to 12	8 to 12	8 to 12	8 to 12	Room Temperature
Bias Voltage (Vdc)	6 to 13	6 to 13	6 to 13	6 to 13	-55 to +125°C
Output Impedance (Ω)	<100	<100	<100	<100	
Full Scale Output Voltage (V)	±5	±5	±5	±5	
Residual Noise (g RMS)	0.0005	0.0006	0.001	0.0025	Broadband 1Hz to 10kHz
Discharge Time Constant (sec)	0.8 to 1.2				
Ground Isolation	Case Grounded				
ENVIRONMENTAL					
Temperature Response (%)	See Typical Temperature Response Curve				
Operating Temperature (°C)	-55 to +125				
Storage Temperature (°C)	-55 to +125				
Humidity	Hermetically Sealed				
PHYSICAL					
Sensing Element	Ceramic (shear mode)				
Case Material	Titanium				
Electrical Connector	4-Pin Receptacle				
Weight (grams)	14				
Mounting	Adhesive				
Calibration supplied:	CS-FREQ-0100	NIST Traceable Amplitude Calibration from 20Hz to ±2dB Frequency Response Limit ²			
Optional accessories:	315-XXX 161	Cable Assembly, 4-pin ¼-28 to 3x BNC (XXX designates length in inches, 10ft standard) Three Channel PE & IEPE Signal Conditioner			

The information in this sheet has been carefully reviewed and is believed to be accurate; however, no responsibility is assumed for inaccuracies. Furthermore, this information does not convey to the purchaser of such devices any license under the patent rights to the manufacturer. Measurement Specialties, Inc. reserves the right to make changes without further notice to any product herein. Measurement Specialties, Inc. makes no warranty, representation or guarantee regarding the suitability of its product for any particular purpose, nor does Measurement Specialties, Inc. assume any liability arising out of the application or use of any product or circuit and specifically disclaims any and all liability, including without limitation consequential or incidental damages. Typical parameters can and do vary in different applications. All operating parameters must be validated for each customer application by customer's technical experts. Measurement Specialties, Inc. does not convey any license under its patent rights nor the rights of others.

Model 7132A Accelerometer

performance specifications

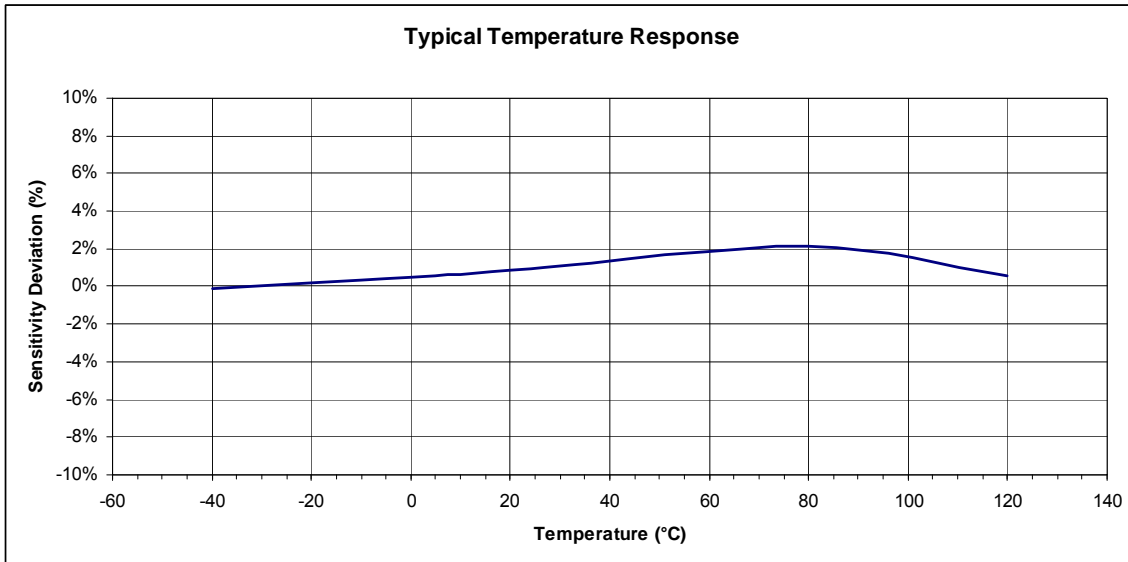
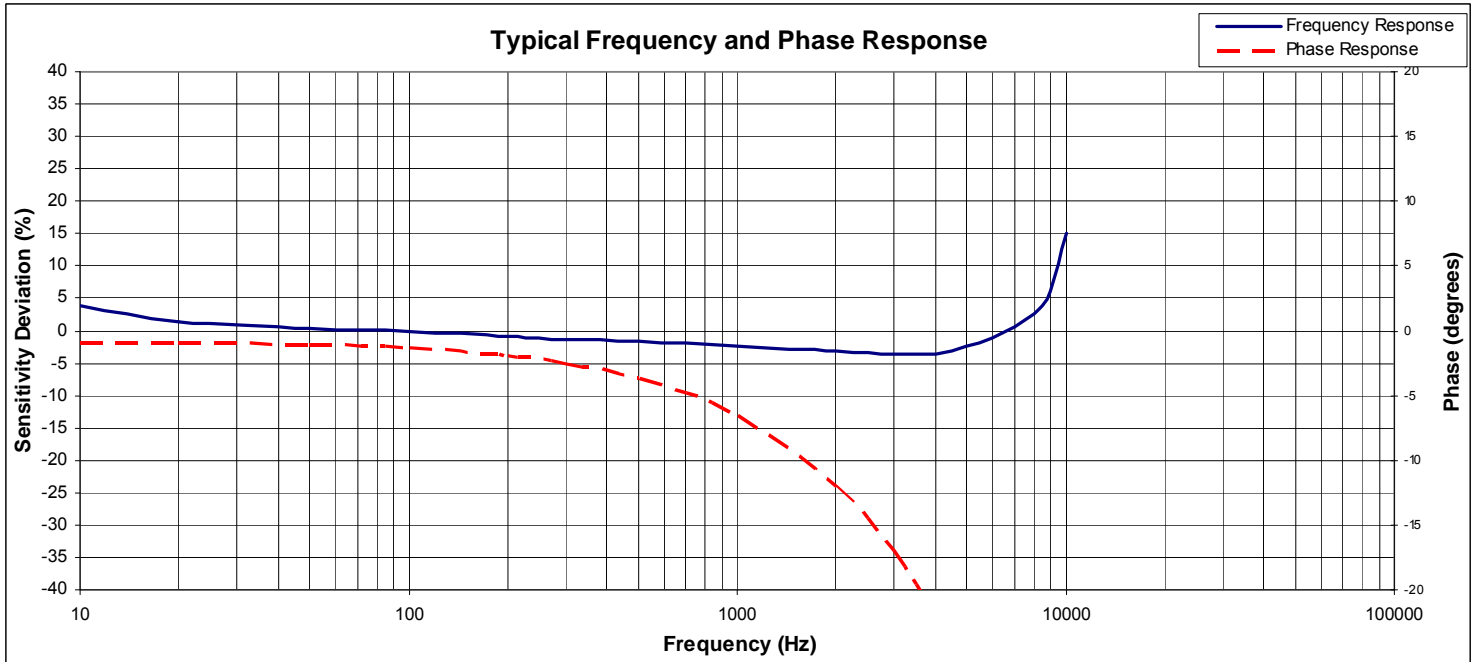

ordering info

PART NUMBERING Model Number+Range

7132AT-GGGG-XX

| | | | Optional Thread Dash Number
| | | | Range (0050 is 50g)
| | | | TEDS compliant to IEEE 1451.4 when 'T' option is included

Dash Number Thread Options
-01 #5-40 UNC-2B
-02 #10-32 UNF-2B
-03 M3 x 0.5 6g

Example: 7132A-0050
Model 7132A, 50g, No Option